



# Owner's Manual PCS PRO



Designed and Manufactured Exclusively by  
Ozotech, Inc.

# Table of Contents

1.0 Limited Warranty	3
2.0 Service Returns	4
3.0 Caution	5
4.0 Theory of Operation	5
4.1 Hi/Low Feature	5
4.2 PCS Corona Discharge Ozone Generation	6
5.0 Operating Conditions	6
5.1 Operating Environment	6
5.2 Input Power Requirements	7
5.3 Figure 1: PCS PRO Ozone Output (mg./hr.)	7
5.4 Figure 2: PCS PRO Ozone Output (%/wt.)	8
6.0 Maintenance	9
6.1 Ozone Generator Maintenance	9
6.2 Corona Discharge Cell Servicing	10
7.0 Spare/Replacement Parts	10
8.0 Fusing	10
9.0 Troubleshooting Guide	11
10.0 Ozone Cell Replacement	12
10.1 Figure 3: PCS PRO component view	12
10.2 Figure 4: PCS PRO typical use diagram	12

## 1.0 Limited Warranty

Ozotech, Inc., warrants the PCS series ozone generators to be free from defects in parts and workmanship for (12) months from date of invoice, under conditions of normal use. The corona discharge cell is warrantied against catastrophic electrical failure for 3 years from date of invoice. All other parts, repaired or replaced, will be warrantied only for the remainder of the original warranty period.

Ozotech, Incorporated will refund the purchase price, perform repairs or replace equipment, at the option of Ozotech, Incorporated.

The warranty shall be null, void, and non-binding upon Ozotech, Incorporated if Ozotech, Incorporated (or authorized service center) determines the cause of malfunction or defect to be a result of:

- 1) Failure to perform proper maintenance as defined and recommended in this manual.
- 2) Failure to adhere to and provide proper operating conditions, as defined in this manual, including operation outside of temperature range, operating in wet or dirty environment, operation outside of manufacturer's specifications.
- 3) Adjustments made by user other than product output flow rate within ranges specified by manufacturer.

Ozotech, Incorporated assumes no liability for damages incurred by deliberate or incidental misuse of this product, or damages incurred in transit.

## 2.0 Service Returns

If the need arises to return your equipment for service, the following procedure must be followed to ensure accurate and timely processing of repairs.

- Obtain the serial number of unit to be returned.
- Obtain model number/name of unit to be returned.
- Contact Ozotech, Incorporated and request a Return Material Authorization (RMA) form. Make sure to give the factory representative an accurate and current shipping address.
- Enclose a description detailing the problem with the unit. Be as specific as possible.
- After receipt of RMA form, package unit for shipment. Enclose the RMA form with the unit. Use the original packaging materials if possible.
- Clearly write the RMA number on the outside of the shipping package.
- Verify that the address is correct and current.
- Shipments that are not factory authorized will be refused.

It is recommended that you ship with a reputable and reliable shipping company, and that the contents of the package are insured. Ozotech, Inc., accepts no responsibility for damage or loss of equipment in transit.

ALL FREIGHT CHARGES INTO THE FACTORY MUST BE PREPAID. If the repair is covered under warranty, the factory will pay return shipping charges (surface rates only) to the address listed on the RMA, within the Continental United States. If the repair is not covered under warranty, the returning party is responsible for payment of return shipping and handling charges, as well as labor and equipment costs associated with the repair.

## 3.0 Caution

Read the following safety guidelines thoroughly before attempting to operate or install your equipment.

As with all electrical devices, this equipment should never be allowed to come in contact with water.

Only qualified personnel should be allowed to set up, maintain and operate this equipment.

- The equipment must be operated using a properly grounded electrical circuit that is protected by either a fuse or circuit breaker.
- Ozotech, Inc., assumes no liability for damages or injuries incurred by misuse of this product.
- Do not use an extension cord to supply power to this equipment.
- Use a Power Conditioner if line voltage fluctuates outside of specified range.
- Unit must be disconnected from power prior to performing service or repair.

## 4.0 Theory of Operation

Your PCS PRO ozone generator is a state-of-the-art device designed to produce ozone. The technology utilized to perform this function is PCS Corona Discharge Ozone Generation. Pulse Modulated Corona Discharge generators create ozone through the action of high voltage, low current electrical “arcs” across an air space. When oxygen ( $O_2$ ) is passed through the air space, some molecules are split, resulting in “free” oxygen atoms which quickly attach themselves to intact  $O_2$  molecules. The result is a very unstable form of oxygen,  $O_3$  (ozone). It is the extra atom of oxygen that gives ozone its superior oxidation capabilities.

### 4.1 Hi/Low Feature

Your PCS PRO ozone generator is equipped with a “Low” and “High” setting. The “Low” setting will produce 220mg/hr. ozone, while the “High” setting will produce 440mg/hr. ozone. Select the setting that best satisfies your needs. Your ozone generator can be seamlessly transitioned between the two settings without additional adjustments.

## 4.2 PCS Corona Discharge Ozone Generation

The PCS technology represents the heart of the ozone generator. As opposed to the plate type air dielectric corona generators, the PCS CD cell is biased with a series of pulsed DC, medium frequency signals within a cylindrical environment. The ceramic dielectrics surround a thin barrier of brass and are then surrounded by a stainless coil held to tight tolerances for length and diameter with high voltage applied, the combination of the brass sleeve, ceramic cylinder and coil provide a condensing action to produce ozone. Improvements in the design have led to a method of producing ozone wherein the cell is: 1) Capable of withstanding high voltage inputs without plating; 2) No relative expansion and contraction of the parts; 3) Able to operate at lower temperatures than conventional corona discharge generators thus improving reliability and efficiency without the need for separate cooling water circuitry; 4) Maximum ozone output with minimum high voltage input.

Each cell(s) is separately housed within its own stainless holding chamber (manifold) with consideration for maximum efficiency. In other words, all the air that is drawn through the chambers is passed directly through the ozone producing region (corona gap) with little or no waste from improper channeling.

See section 6.2 for CD cell service procedure.

## 5.0 Operating Conditions

Your generator requires special operating conditions in order to maintain performance and reliability. Your ozone generator is designed to be operated under a negative or positive pressure situation. Your Ozotech ozone generator has been factory tested to operate at a maximum positive pressure of **5 psi**. Warranty coverage of your equipment is contingent upon strict compliance with the operating conditions specified in this manual.

### 5.1 Operating Environment

#### External

It is most important to choose a cool, clean external operating environment. Consideration of these factors should be a priority. Mount your ozone generator in the best possible operating environment that is available at chosen site. If possible, mount in an area that is free of airborne moisture particles.

#### Internal

Keep the inside of the generator chassis clean and dry. Dust particles and condensation pose a challenge to the consistent operation of all ozone generators. Make a note to inspect the internal cleanliness of the equipment when you perform your scheduled maintenance. For further information refer to section 6.0.

## 5.2 Input Power Requirements

Ozotech, Inc., offers the PCS PRO ozone generator in a variety of configurations to accommodate a wide range of applications. Configurations include a standard AC to DC wall transformer, a cigarette lighter adapter or twisted wire for connection to a hard 12 VDC source such as a car, boat or RV battery circuit. Most supply voltages fluctuate, so it is necessary to monitor your voltage and assure it is within acceptable variance values listed below.

Voltage = (Specified) 11.7 VDC to 13.9 VDC

Frequency = Not applicable

Power Consumption = 700mA to 1.3A @12vdc (8.4 to 15.6 watts) nominal

## 5.3 PCS PRO Ozone Output (mg./hr.)

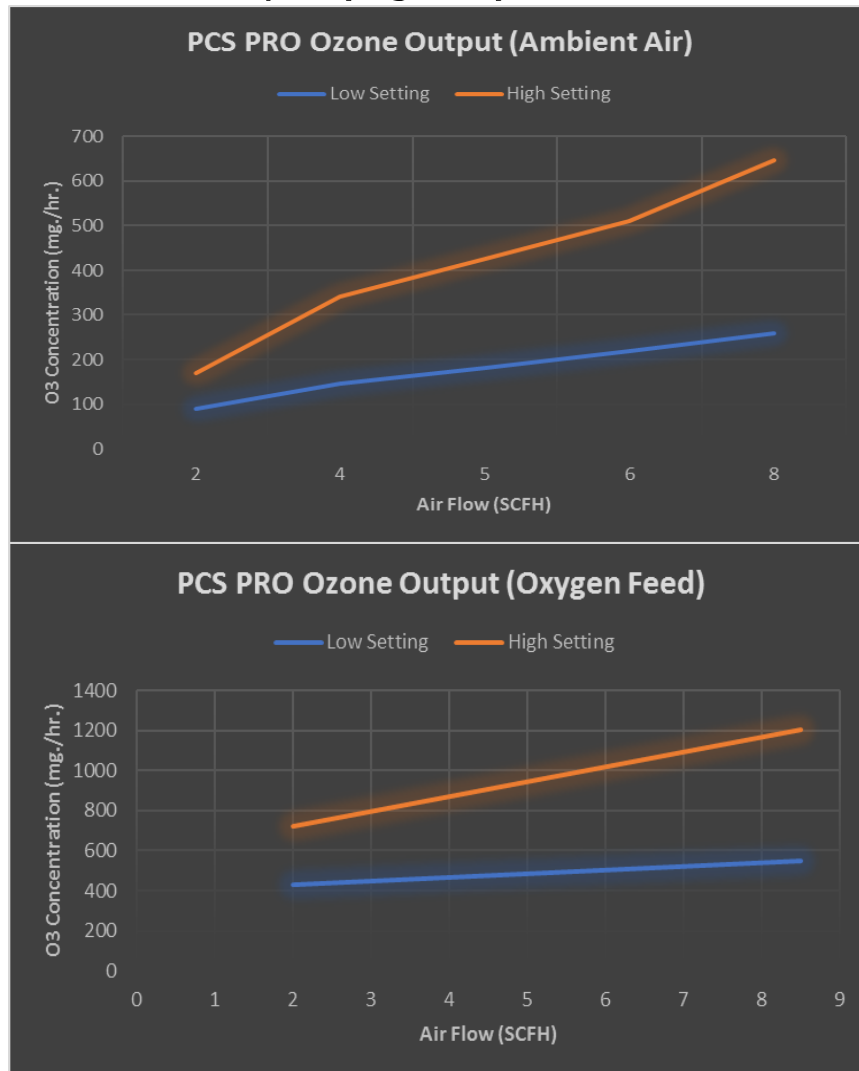
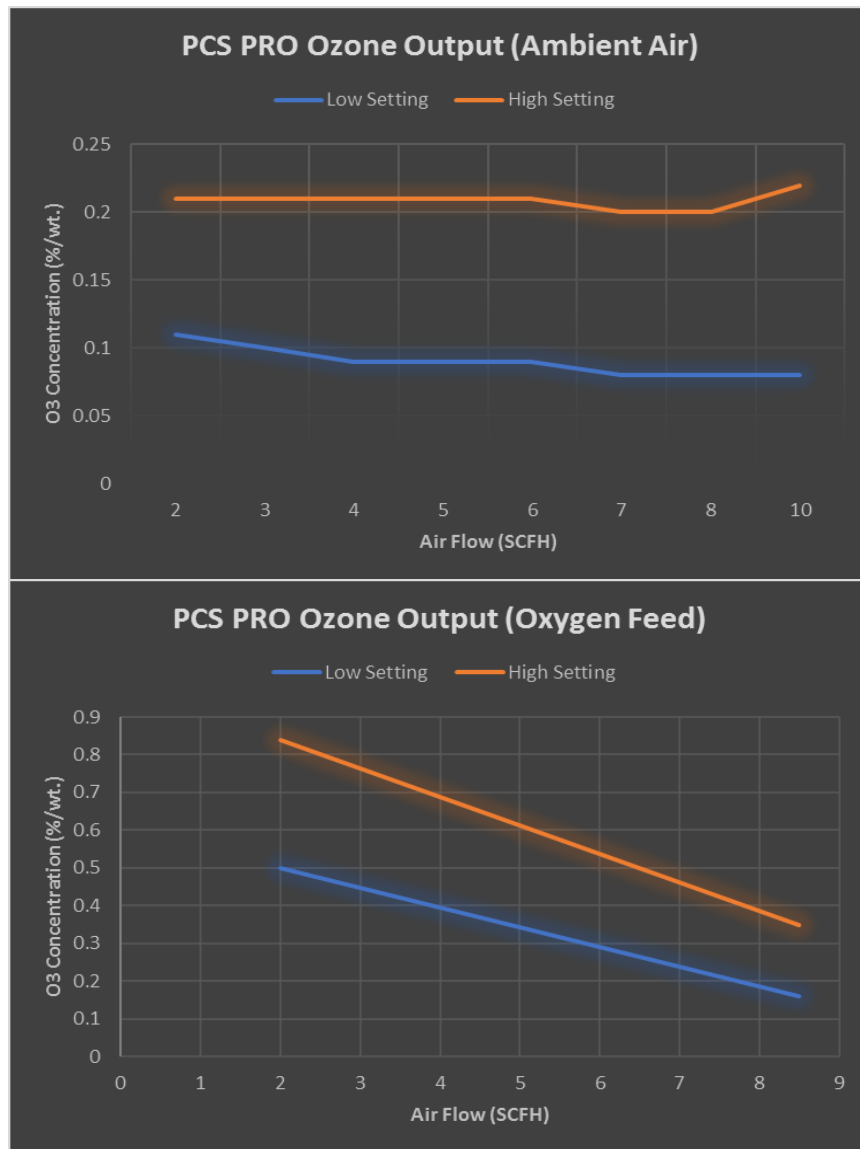

Figure 1: PCS PRO ozone output measured in mg./hr.

## 5.4 PCS PRO Ozone Output (%/wt.)



**Figure 2:** PCS PRO ozone output measured in %/wt.



## 6.0 Maintenance

The PCS generators are delivered factory tested, calibrated, and adjusted for maximum efficiency and long life. Simple maintenance and appropriate operating conditions are the only requirements to keep the unit functioning within manufacturer's specifications.

Performing any other modifications or adjustments to internal components will cause the unit to function outside of manufacturer's specifications, and will cause damage to the unit not covered under terms of warranty.

### 6.1 Ozone Generator Maintenance

#### Frequency of Maintenance

Every 4800 hours (6 months)

#### To maintain the Ozone Generator:

1. Disconnect unit from power source.
2. Remove front cover.
3. Inspect the inside of the generator for dust and moisture.
4. Thoroughly clean and dry the inside of the generator.
5. Replace front cover.
6. Replace any ozone resistant check valves on the air in or ozone gas outlet lines.

## 6.2 Corona Discharge Cell Servicing

The Corona Discharge (CD) cell is an item that will require periodic maintenance. Electrical failure is usually the result of a mechanical failure. For example, should the cell become plugged with nitric byproducts or should water back into the cell, it could be the cause of an electrical failure. Proper air preparation can usually avoid the build-up of nitrous but may be cost prohibitive in some applications as the cost of a replacement cell is minimal. Refer to the diagrams at the end of this manual for the typical unit layout. Ozotech Inc. offers a CD cell cleaning kit for easy maintenance of your CD cells installed within your PCS PRO ozone generator. It is recommended to use this kit to thoroughly clean your CD cells every 6 months or sooner depending on operating conditions to ensure maximum ozone output. Having a spare CD cell already cleaned and dried on hand can save service time when performing this procedure.

## 7.0 Spare/Replacement Parts

(\*) Denotes recommended spare maintenance parts with initial purchase. Followed by quantity, per unit, recommended for one year's scheduled maintenance.

<u>Part #</u>	<u>Description</u>
33217-B	Corona Discharge Cell
31500-2	Combo Board
47018-303/304	Kynar Check Valve (3/16"x1/4") *1
40080-01	Wall Transformer, 115 VAC to 12 VDC Regulated, 2A (Domestic Customers Only)
47044-1	CD Cell Maintenance Kit *1

## 8.0 Fusing

There is one fuse per combo board connected to the 12 VDC source. They are located on the component side of each combo board. Fuse size and value is listed below:

<u>Part Number</u>	<u>Fuse Size</u>	<u>Fuse Value</u>
43223	Type IEC 127	.800 amp, fast blo

## 9.0 Troubleshooting Guide

Symptom	Possible Cause	Remedy
Unit does not turn on.	Unit is not connected to power source, or is connected to improper power source.	Refer to label on side of chassis for voltage/frequency requirements.  Connect unit to proper power source.
	ON/OFF switch not turned to the "HIGH/LOW" position.	Turn switch to HIGH/LOW position
	Blown fuse	Replace fuse with equally rated substitute
Unit keeps blowing fuses.	Electrical short circuit.	Visually inspect unit, and check for loose connections. Inspect printed circuit board for burn marks. Inspect HV wire from printed circuit board to ozone cell for disconnection or burn marks. Repair all problems prior to placing unit in service, or contact factory for service information.
	Incorrect fuse value and type are being used.	Replace with appropriate size/type fuse. Refer to Spare/Replacement Parts for replacement part information.
	Unit is connected to improper power source.	Refer to label on side of chassis for correct voltage requirements.
Unit is yielding approximately ½ of rated output.	Improper power source.	Refer to label on the side of the unit to ensure that unit is plugged into proper voltage outlet.
Unit turns on, but no ozone output	Combo board is defective	Replace combo board.
	Frequency driver high voltage lead (s) not connected to ozone cell(s).	Connect lead(s) to Corona Discharge Cell(s).
	Water has been allowed to back up into the cell and cause a direct short.	Refer to CD cell cleaning kit instructions.
	Cell is plugged with a build-up of nitrous byproducts and particulate matter. This is usually caused by the lack of proper air preparation.	Refer to CD cell cleaning kit instructions.

## 10.0 Ozone Cell Replacement (Refer to Figure 3)

1. Disconnect unit from power source.
2. Remove Chassis Cover.
3. Disconnect the HV wire that is connected to the male spade lug on the printed circuit.
4. Disconnect all tubing from the cell(s). Pull the cell(s) out of the fuse clips and set aside.

Reverse steps 1 thru 3 to install a new cell(s)

### 10.1 Illustrations

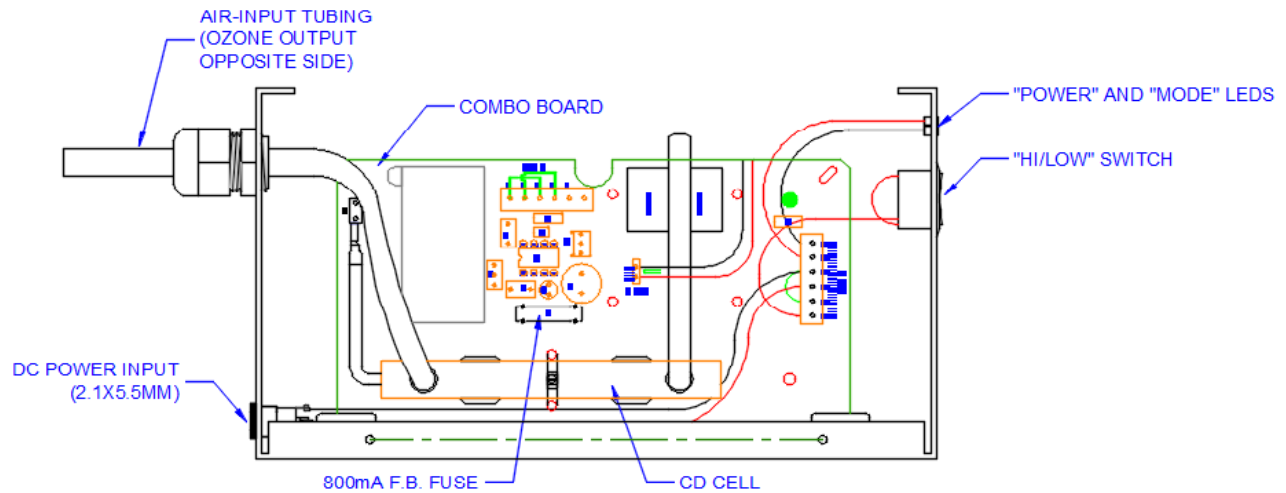

Figure 3: PCS PRO component view

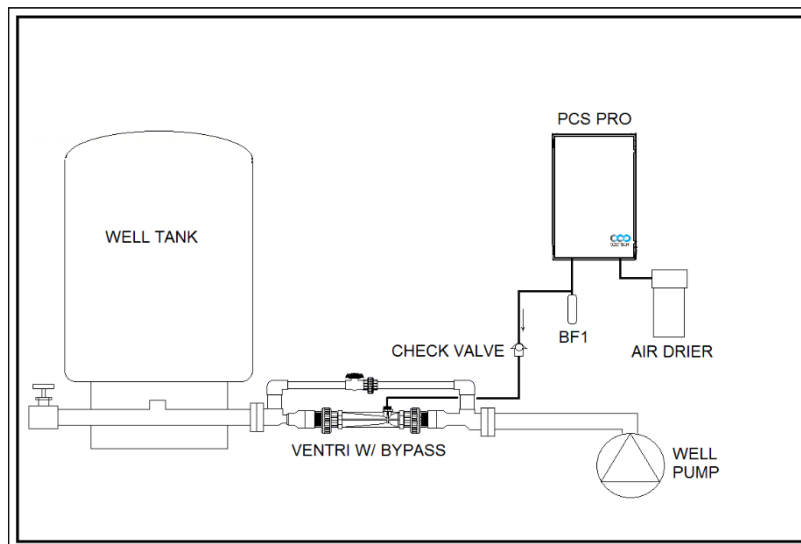

Figure 4: PCS PRO typical use diagram