

OZOTECH

AIM BTU 1000 & 2000 Ozone Generator Quick Start Guide

Reference this quick start guide to install and set up your new AIM Series Ozone Generator for service. Please refer to the full manual (available online at ozotech.com) for additional information including maintenance and operating conditions.

1) Unpack & Inspect Components - Unpack the ozone generator, parts and accessories, and compare to this packing list:

OZONE GENERATOR

Quantity	Item #	Description - Use
(1)	31334 or 31335	1000 Mg/Hr or 2000 Mg/Hr AIM Series Ozone generator
(1 or 2)	40155	50mm x 22 inch glass "Cool Tube" Corona Discharge Cell
(1 or 2)	44347-1	AIM series "Cool Tube" spring tension retainer
(1)	38001	115V AC power cord with plug
(1)	44073 & 44074	Power cord gripper grommet and nut
(2)	43230	Spare Fuses—3.15 Amp, slow blow

ACCESSORIES

Quantity	Item #	Description - Use
(1)	M43-31335	User Manual
(1)	T40-32001	Venturi Install and Care Guide
(1)	31011	BF1 - Back Flow Prevention Device
(60")	44244-1	Ozone Resistant 1/4" ID tubing
(24")	44141-1	Ozone Resistant 3/8" ID tubing
(1)	33258-01	Accessory Hose Adapter Kit, as follows:
(4)	44144	#2 Snapper Clamp - use with 3/8" OD hose
(4)	44134	#4 Snapper Clamp - use with 7/16" OD hose
(4)	44096	#7 Snapper Clamp - use with 1/2" OD hose
(6)	44071	#10 Snapper Clamp - use with 9/16" OD hose
(2)	44112	#14 Snapper Clamp - use with 5/8" OD hose
(3")	44208	Ozone Resistant 1/2" ID x 5/8" OD tubing - use to step up tube size
(3")	44095	Ozone Resistant 3/8" ID x 1/2" OD tubing - use to step up tube size
(2")	44140	Ozone Resistant 1/4" ID x 3/8" OD tubing - use to step up tube size
(2)	46012	Ozone Resistant Tubing Insert 1/4" - use with soft or thin wall tubing
(4)	44249	Ozone Resistant Hose Connector 1/4" to 1/4" barb
(1)	44247	Ozone Resistant Hose Connector 1/4" to 3/8" barb - use to step up tube size
(1)	44248	Ozone Resistant Hose Connector 3/8" to 1/2" barb - use to step up tube size
(2)	47018-304	Ozone Resistant Check Valve 1/4" barb

2) Physical Mounting

Choose a location for your AIM Series Ozone Generator that is clean, dry, and free of excessive dust. Your equipment requires a constant flow of clean air for proper internal cooling. A minimum of six (6) inches clearance is required around the front, bottom, and sides of the unit to ensure proper air flow. Clearance of 30" is recommended at the top of the unit for access to the glass tubes inside the corona discharge chambers.

Direct exposure to moisture must be avoided. The AIM Series Ozone Generator chassis is designed to be drip-proof. It is not water-tight.

The AIM Series Ozone Generator is designed to be mounted vertically on a wall or panel or frame work. There are four (4) key hole shaped mounting holes sized for #8 machine screws. Additional holes may be drilled through the back panel as needed for custom installations. See drawing at right for factory mounting-hole spacing.

Handy Tip: To better facilitate top lid removal, space the unit out from the wall slightly (about 1/8") and be sure to leave adequate clearance at the top to access and remove glass tubes.

CHASSIS - BACK VIEW

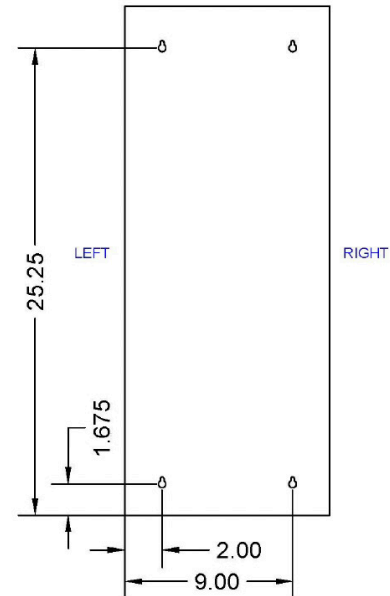

3) Electrical Connections

The latest model of the AIM Series Ozone Generators are designed to accept either 115VAC or 230VAC (in 50 or 60 Hz) as incoming supply power. The supply power drop should be sized to supply 250 watts and should include an appropriate circuit breaker and disconnect.

If the unit is to be used with 115VAC supplied via a standard US style, 3-prong outlet, then the supplied power cord should be used. If the unit is to be supplied power alternatively, then a customer supplied connection is required.

To make the connection simple and quick, a "press-to-release" screwless terminal block is provided in the machine to receive incoming power wires. See pictures below for each connection option.

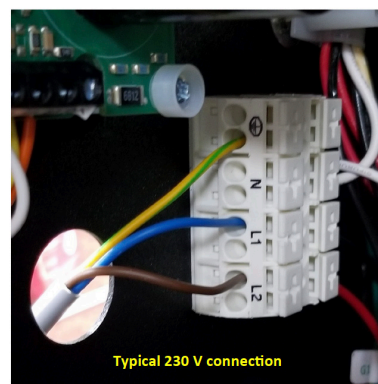
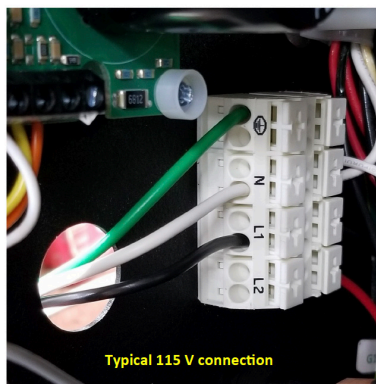

4) Install Glass Corona Discharge Tubes

Your AIM Series Ozone Generator is shipped from the factory with the glass “Cool Tube” Corona Discharge Cells packaged separately to protect them from in-transit shipping damage. Before you can operate your ozone generator, these tubes need to be installed. Reference the diagrams and follow the steps below to properly install these components:

Step 1— a) Remove power to the machine by unplugging it or turning off disconnect. b) Loosen four (4) top cover screws and remove top cover. c) Remove five (5) access door screws and carefully open front door cover.

Step 2— a) Inspect arrangement of high voltage wires; Take a picture or notes to ensure wires are placed back in the same manner after tubes are installed. b) Remove CD Cell Caps (item 45264-03), using a 1/4" (6.5mm) socket with extension or similar tool. High voltage wires do not need to be disconnected to remove caps; let them hang gently to the side.

Step 3— a) Place tube holder/spring tension retainer (item 44347-1) into the bottom of each chamber. Inspect placement to ensure spring retainer is not sideways or upside down.

Step 4— a) Carefully insert a glass corona tube (item 40155) into each chamber. Ensure the brass electrode end is up (towards cap end).

Step 5— a) Reinstall caps onto manifold(s) (making sure o-rings are properly seated in cap flange). The Corona Tube will be spring loaded and the cap will need to be gently pressed down to install the nuts. Ensure that the high voltage wire guide is positioned correctly and that the faraday shield ground wire ring terminal is under one of the nuts for each cap.

Follow the nut (standoff) tightening order and torque spec in the diagram below:

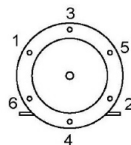

STAND-OFF TIGHTENING ORDER
(TIGHTEN STAND-OFF #1 THEN #2 THEN #3, ETC...)
(TORQUE TO 15 INCH POUNDS)

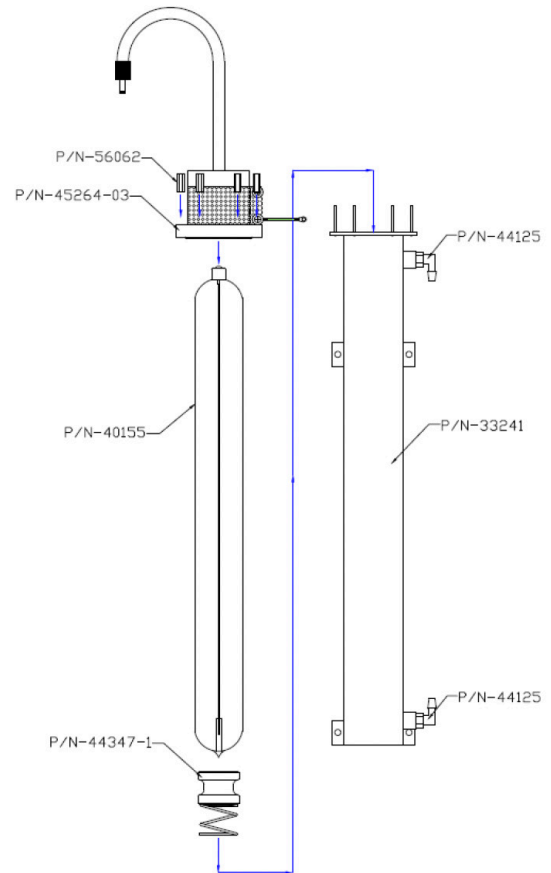

Step 6— a) Close the front cover door being careful to not pinch hoses or wiring harness. Reinstall the five (5) door screws . b) Reinstall the top cover and secure with the four (4) top cover screws.

Your AIM series ozone generator is now ready to connect to your feed gas input and ozone output lines.

5) Inlet and Outlet Hose Connections

The AIM Series Ozone Generator is designed to feed ozone to a variety of applications with a minimum flow rate of 3 SCFH and a maximum of 20 SCFH. Lower pressures and flow rates generally achieve best performance. A variety of hose connectors and adapters are provided in the hose adapter kit to step-up or down hose sizes, to fit your application. The AIM Series Ozone Generator may be used in both positive and negative pressure applications. The use of snapper clamps on all positive pressure application connections is recommended.

Positive pressure feed applications— It is recommended that pure oxygen from a tank or concentrated oxygen from an oxygen concentrator machine be used to supply the feed gas for optimum performance, but clean dry air can also be used. Compressed air or gas must be pressure regulated to 5 psi or less. Lower pressures and flow rates generally achieve best performance. Connect the feed gas supply to the inlet hose (closest to the access door) and connect ozone feed line to the outlet hose (closest to back of chassis). Turn on gas flow and fine tune the flow rate to suit your application by adjusting the flow meter knob on the front door of the AIM Series Ozone Generator. Temporarily installing an inline or T-branch manometer, or other fine resolution pressure sensing instrument, on the outlet hose is a good way to verify internal pressures are not too high. A check valve in the ozone outlet line must be installed between the ozone generator and delivery device.

Negative pressure applications—This machine can be used with vacuum draw systems as well, provided the minimum air flow rate (3 SCFH) and internal chamber pressures (≤ 5 psi) requirements are met. Like positive pressure applications, it is recommended that bottled or concentrated oxygen feed gas be used to supply the ozone generator. Connect the inlet and outlet tubing in the same fashion as described above. Install the supplied BF1 - Backflow Prevention Device between the ozone generator and inline check valve on the ozone output line.