



Ozone Generators

AIM 2 BTU and AIM 5 BTU Ozone Generators Operation & Maintenance Manual

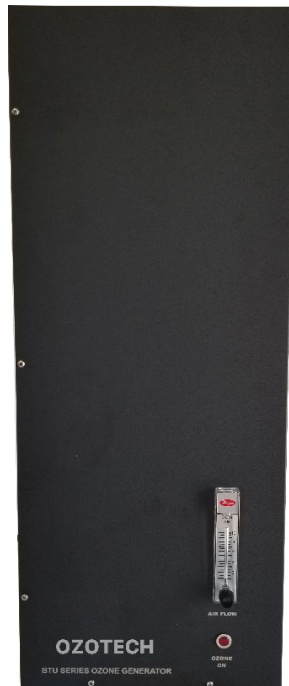

TABLE OF CONTENTS

1.0	Caution	1
2.0	Theory of Operation	2
2.1	Cold Plasma Corona Discharge Ozone Generation	2
3.0	Operating Conditions	2
3.1	Operating Environment	2
3.2	Internal Air Flow Specifications	3
3.3	Preparation of Input Air	3
3.4	Input Power Requirements	4
4.0	Maintenance	5
4.1	Corona Discharge Cell Maintenance	5
4.2	Intake Filter Maintenance	9
4.3	Chassis Maintenance	9
4.4	Check Valve Replacement	10
5.0	Fusing	12
6.0	Spare/Replacement Parts	13
7.0	Troubleshooting Guide	15
8.0	Standards	16
9.0	Limited Warranty	17
10.0	Service Returns	18

LIST OF FIGURES

Figure 1 CD Cell Interface, (Component Descriptions)	6
Figure 2 CD Cell Cap Removal & Installation	7
Figure 3 CD Cell & Manifold Component Layout	8
Figure 4 Check Valve Assembly, (Detail)	10
Figure 5 Check Valve Installation, (Detail)	11
Figure 6 Fuse Location, (Left Side Chassis Component Details)	12
Figure 7 AIM 2 BTU and AIM 5 BTU Mounting Hole Locations	16
Figure 8 AIM 2 BTU, WIRING DIAGRAM, 115vac 50/60Hz.	19
Figure 9 AIM 2 BTU, WIRING DIAGRAM, 230vac 50/60Hz.	20

1.0 Caution

Read the following safety guidelines thoroughly before attempting to operate or install your equipment:

- As with all electrical devices, this equipment should never be allowed to come in contact with water.
- Only qualified personnel should be allowed to set up, maintain and operate this equipment.
- The equipment must be operated using a properly grounded electrical circuit.
- Ozotech, Inc., assumes no liability for damages or injuries incurred by misuse of this product.
- Do not use an extension cord to supply power to this equipment.
- Use a power conditioner if line voltage fluctuates outside of specified range.
- Unit must never be run with internal air flow rate below manufacturer's specifications.
- Unit must be disconnected from power prior to performing service or repair.

2.0 Theory of Operation

Your AIM 2 BTU, and AIM 5 BTU ozone generators are a state-of-the-art device designed to produce significant concentrations of high-purity ozone. The technology utilized by Ozotech, Inc., to generate ozone is known as "Cold Plasma Corona Discharge".

2.1 Cold Plasma Corona Discharge Ozone Generation

Cold plasma corona discharge generators create ozone through the action of extremely high voltage, low current electrical "arcs" across an air space. When oxygen (O_2) is passed through the air space, some molecules are split, resulting in "free" oxygen atoms which quickly attach themselves to intact O_2 molecules. The result is a very unstable form of oxygen, O_3 (ozone). It is the extra atom of oxygen that gives ozone its superior oxidation capabilities.

As opposed to plate-type or open-air dielectric corona discharge generators, cold plasma corona discharge utilizes a cell filled with proprietary gases. The cell (or cells) are then surrounded by a perforated stainless steel grid, connected to earth ground. When high voltage is applied to the cell, an electrical arc, called "corona" is formed between the cell and the grid.

Each cell/grid combination is separately housed within its own holding chamber (manifold). All air drawn through the manifold is channeled directly through the corona. This design surpasses plate-type corona discharge designs by constantly exposing a fresh supply of oxygen molecules to the corona, and by keeping the cell and manifold cool. Recent improvements in the design have led to a method of producing ozone wherein the cell is: 1) Capable of withstanding high voltage inputs without plating; 2) No relative expansion and contraction of the parts; 3) Able to operate at lower temperatures than conventional corona discharge generators thus improving reliability and efficiency without the need for separate cooling water circuitry; 4) Maximum ozone output with minimum high voltage input.

3.0 Operating Conditions

Your ozone generator requires special operating conditions in order to maintain performance and reliability. Warranty coverage of your equipment is contingent upon strict compliance with the operating conditions specified in this manual.

3.1 Operating Environment

EXTERNAL

Choose a location for your equipment that is clean, dry, and free of excessive airborne particles. Your equipment requires a constant flow of clean air for proper internal cooling. A minimum of six (6) inches clearance is required around the front, bottom, left and right side of the unit to eliminate restriction of air flow. Direct exposure to moisture must be avoided. The ozone generator chassis is designed to be drip-proof. It is not water tight.

Mount your ozone generator in the best possible operating environment available at your installation site.

INTERNAL

The operating environment inside the chassis is also important. Maintaining a clean, dry unit will increase overall performance and extend service life. A common cause of failure is un-contained corona (electrical arcs) within the chassis environment. Moisture and dust are facilitators of this condition. They both help set up a “path” for the corona to develop and follow. Once established, corona usually does not stop until it has become severe enough to cause catastrophic failure of the corona discharge cell or manifold, and subsequently blows the fuse. **Note:** If this condition develops, contact manufacturer.

3.2 Internal Air Flow Specifications

As mentioned in the Theory of Operation section, cold plasma corona discharge relies upon a flow of air passing between the corona discharge cell and the perforated grid to produce ozone and keep the corona cell and manifold cool.

The rate at which air is drawn (or forced) through the ozone generator is user adjustable. You may fine tune the flow rate to best suit your specific application. However, in no case should the air flow rate be allowed to drop below the minimum values specified below. Failure to provide minimum air flow rates may allow your ozone generator to develop too much heat, possibly leading to equipment failure.

Minimum Air Flow Rate in

Model	Standard Cubic Feet per Hour (SCFH)
AIM2BTUSL	3
AIM5BTUSL-SS	6

3.3 Preparation of Input Air

Regardless of the method of ozone generation, properly preparing the input air (feed gas) will pay huge dividends in performance and reliability. Ozotech, Inc., does not recommend the use of any BTU series ozone generator without air preparation. Warranty coverage of your ozone generator is contingent upon operation with air preparation equipment.

The key to air preparation is in the removal of Hydrogen (H) and Nitrogen (N) found in ambient air. When atoms of Hydrogen and Nitrogen are subject to corona discharge (cold spark or otherwise), by-products such as Nitrous acid (HNO_2) and Nitric acid (HNO_3) are formed. The formation of these compounds inhibits performance and increases the frequency of maintenance.

To understand how performance is affected, we must recall from the Theory of Operation section that ozone is created by splitting an oxygen molecule (O_2), and then joining the liberated oxygen atoms (O) with intact oxygen molecules.

Imagine that in addition to oxygen molecules, your feed gas also contains Hydrogen and Nitrogen atoms.

After being subjected to corona, some of the Hydrogen and Nitrogen atoms will attach themselves to intact oxygen molecules, forming HNO_3 , or Nitric acid. Others will attach themselves to ozone molecules, forming HNO_2 , or Nitrous acid. It is the formation of these compounds that reduces performance potential. It is simple to understand why. If ozone molecules were not being “used” by Hydrogen and Nitrogen in the formation of acids, more would be available to be used in oxidation. Likewise, if oxygen molecules were not “used” to form acids, they would be available for the creation of more ozone.

Increased service life and reduction in maintenance are gained due to the same principle. With less HNO_2 and HNO_3 being formed, corona discharge cell maintenance, or cleaning the cell, can be reduced without the risk of acid buildup. Since both HNO_2 and HNO_3 are highly conductive, they are capable of producing a path for corona (electrical arcs) outside of the corona discharge cell and manifold. As stated previously, once an arc has started, catastrophic failure is the usual result.

Your ozone generator is capable of operating with either negative pressure or positive pressure air preparation devices. Negative pressure devices, such as heat-regenerated desiccant air dryers rely upon the action of the venturi injector to draw air through the generator (and the dryer). This method is typically not utilized with the BTU series, due to the difficulties of meeting minimum air flow requirements through the vacuum action of a venturi injector alone. Positive pressure devices, such as the Power Prep Series manufactured by Ozotech, Inc., utilize an internal air compressor to push prepared air through the generator. This method is utilized in the majority of BTUSL applications.

Your BTU series ozone generator is designed for not more than 50 psi of internal pressure.

3.4 Input Power Requirements

Ozotech, Inc., offers the BTU series ozone generators in a variety of configurations to accommodate a wide range of world supply voltages and frequencies. Refer to voltage label on the side of the unit for specific voltage and frequency requirements. It is extremely important that your equipment is provided with the appropriate operating power source. Most supply voltages fluctuate, so it is necessary to monitor your voltage and assure it is within acceptable variance values listed below.

Voltage = (Specified) +/- 5%

Frequency = (Specified) +/- 5%

Power Consumption, AIM 2 BTU = Nominal 65 Watts(60Hz), 92 Watts (50Hz)

Power Consumption, AIM 5 BTU = Nominal 105 Watts(60Hz), 145 Watts (50Hz)

Note: If your line voltage fluctuates beyond acceptable variance, it will be necessary to connect your equipment to a line conditioner.

4.0 Maintenance

The AIM 2 BTU and AIM 5 BTU are designed and delivered for maximum efficiency and long life. No adjustments, other than fine-tuning the air flow rate to match user-specific requirements, should be made by the end user. Simple maintenance and appropriate operating conditions are the only requirements to keep the unit functioning within manufacturer's specifications.

Performing any other modifications or adjustments to internal components will cause the unit to function outside of manufacturer's specifications, and will cause damage to the unit not covered under terms of warranty. Maintenance should only be performed by qualified individuals. Your ozone generator operates under conditions of high voltage; maintenance personnel should be trained in electrical safety.

4.1 Corona Discharge Cell Maintenance

Corona discharge cell maintenance is simply a matter of keeping the cells clean and ensuring the O-ring seat is in good condition. Depending on your model, you will have either (1) or (2) cells to maintain. Ozotech, Inc., has designed a cell-to-chamber interface that restricts the corona discharge to only the stainless steel manifold, thereby reducing any possibility of catastrophic failure due to heat or high voltage arcing.

Frequency of Maintenance: Every 4800 hours (3 months)

To maintain the corona discharge cells:

1. Disconnect unit from power source. Allow generator and room to clear of ozone gas.
2. Loosen the (4) screws securing the chassis lid and remove the lid assembly.
3. Locate the high voltage wire(s) connected to the top of each corona discharge cell. Pay close attention to the wire routing. It will be necessary to route in the same manner when maintenance is complete. Note: In any case, wires must be routed so that a minimum clearance of 1 inch is provided between wire and chassis (or metal parts attached to chassis).
4. Remove the high voltage cap from the top of each "corona discharge cell" by carefully loosening and removing each of the Nylon stand-offs that secure the H.V. Cap(s) onto the manifold(s). (See Figure 2)
5. Very carefully pull each CD cell, straight out of the manifold assembly. Your "corona discharge cell(s)" are made of glass, so extreme care must be taken to avoid breakage!
6. Clean the entire cell (glass as well as cap) with glass cleaner, or soap and water. DRY THOROUGHLY. **Note:** Replacing a wet Cell will cause damage to the unit.
7. Install corona discharge cells by reversing steps 3 through 5. Route high voltage wires as close to original routing as possible, as shown in Figure 3. The object is to separate these wires from sources of ground, such as the chassis, and low voltage (115 or 230V) components.
8. Pressure check your unit. With the unit powered down and supplying a source of positive pressure, open the airflow meters until the indicating ball reaches the top of the scale. Remove the ozone delivery tubing from the venturi injector inlet (or equivalent) and seal to begin to pressurize the generator and ozone delivery tubing. Using a suitable leak check solution (available through your Ozotech, Inc., dealer) check for leaks at the tube/chamber interface, tubing connections, etc. Immediately correct any leaks prior to placing your unit back in service.

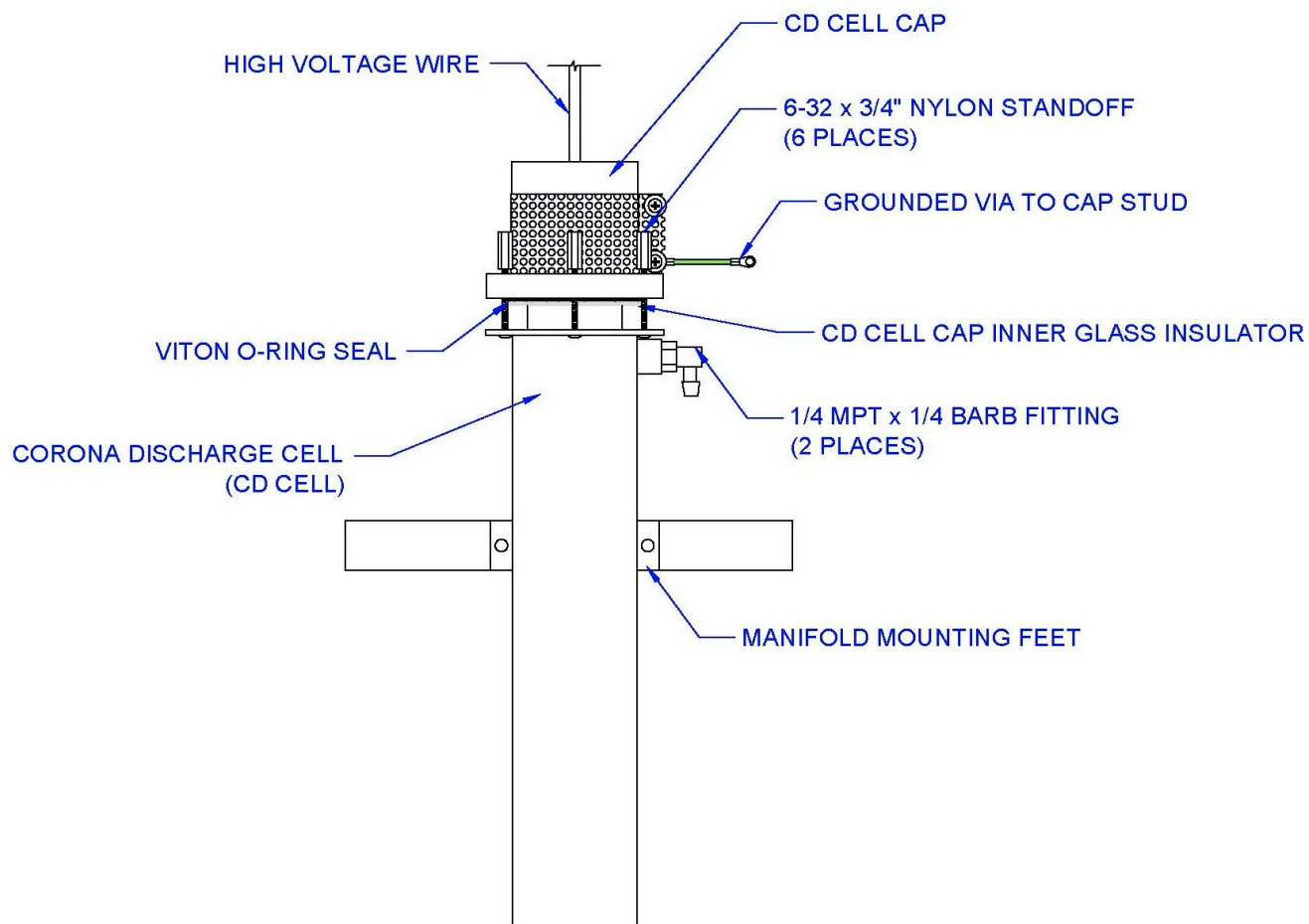
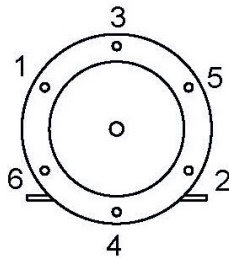
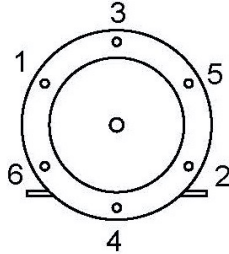

FIGURE 1 – CD Cell INTERFACE, (COMPONENT DESCRIPTIONS)



STAND-OFF LOOSENING ORDER
(REMOVE STAND-OFF #1 THEN #2 THEN #3, ETC...)

NOTE: THE CD CELL IS UNDER SPRING TENSION!
TO AVOID THE CAP CAUSING POSSIBLE DAMAGE TO THE CD CELL HOLD THE
CAP DOWN WHILE REMOVING THE LAST TWO STAND-OFFS.
CAREFULLY REMOVE THE CAP STRAIGHT UP



STAND-OFF TIGHTENING ORDER
(TIGHTEN STAND-OFF #1 THEN #2 THEN #3, ETC...)
(TORQUE TO 15 INCH POUNDS)

FIGURE 2 – CD Cell CAP REMOVAL & INSTALLATION

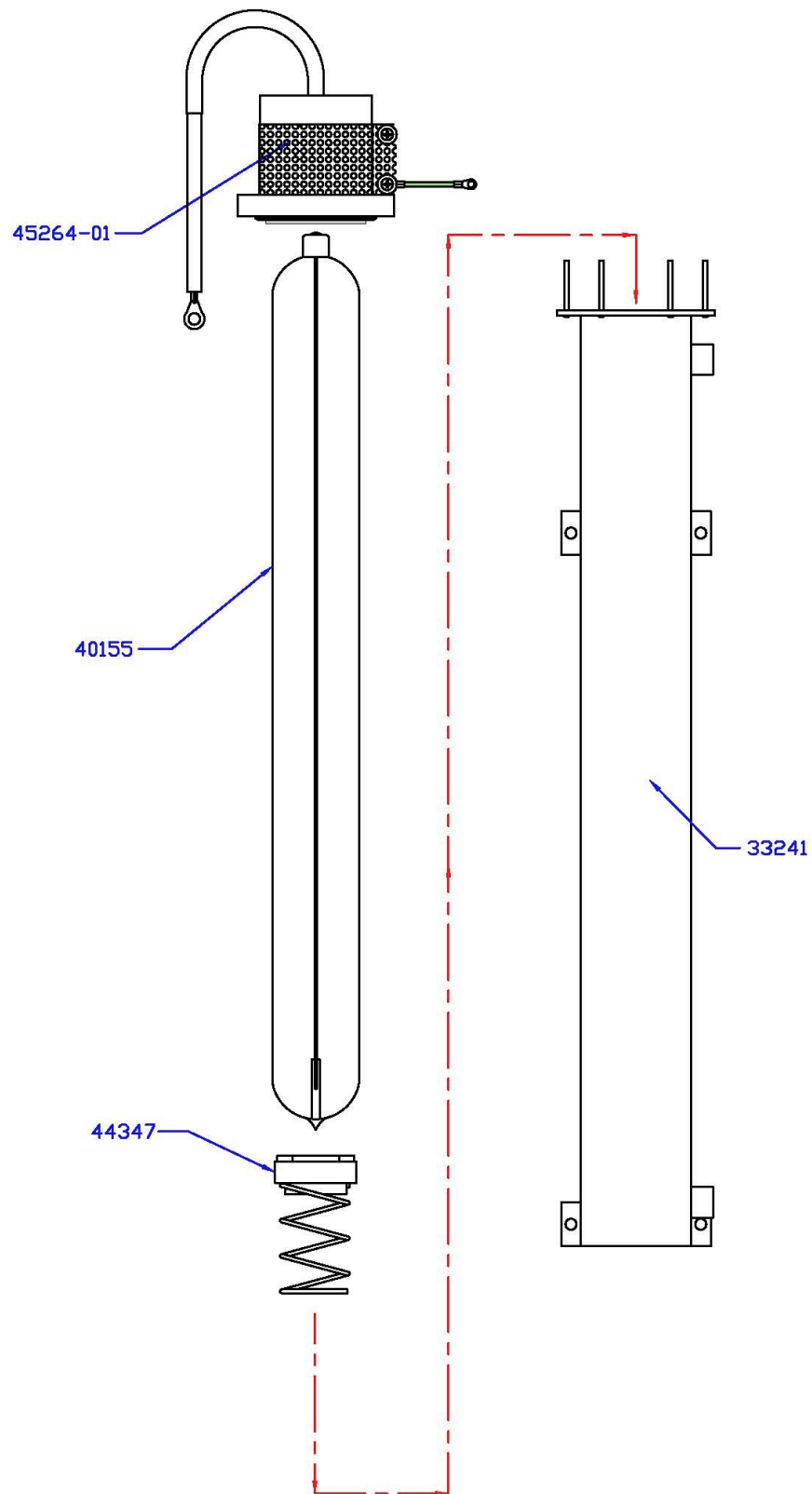

FIGURE 3 – CD Cell & MANIFOLD COMPONENT LAYOUT

4.2 Intake Filter Maintenance

The intake filter is located on the side of the chassis, Figure 10. This filter removes dust particles from the air drawn into the chassis. Proper cooling of internal components requires filters to be clean, dry and intact.

Frequency of Maintenance: Every 2,400 hours (3 months)

To Clean Intake Filter

1. The filter retaining ring snaps into grooves in the fan guard. Remove filter retaining ring by gently pulling on one side.
2. Remove filter media. Wash gently in soap and water. Dry thoroughly. Inspect for tears, holes, etc. If filter is intact, replace by reversing Step 1.

Note: Depending on the severity of your specific environment, it may be necessary to increase frequency of maintenance.

Frequency of Replacement: Every 4800 hours (6 months)

To Replace Intake Filter

Replacement procedure is identical to maintenance procedure.

Note: Depending on the severity of your specific environment, it may be necessary to increase frequency of maintenance.

4.3 Chassis Maintenance

Proper maintenance of your generator chassis will provide more than aesthetic advantages. Dust and moisture can contribute to a path for electrical arcs. A clean internal environment will reduce the likelihood of corona outside of the corona cell and manifold.

Frequency of Maintenance: Every 2,400 hours (3 months)

To Maintain Chassis

1. Disconnect unit from power source.
2. Remove chassis lid and access cover
3. Using a clean, dry cloth, carefully wipe off inside of chassis and all internal components. Make certain that the tops of the corona cell(s), the "face" of the transformer, and the high voltage wire(s) are thoroughly cleaned.
4. Using a damp cloth, clean the outside of the unit. A mild detergent may be used.
5. Thoroughly dry chassis, inside and out.

4.4 Check Valve Replacement

Protecting your ozone generator from water infiltration is vital. Ozone generators will fail if water is allowed to enter the corona region. Water infiltration can be avoided by proper installation and maintenance of a back flow prevention device between the ozone generator "Ozone Outlet" and the venturi injector (or diffuser).

We strongly suggest that the check valve is closely inspected as often as possible, such as each time maintenance of any type is performed. If water is visible between the check valve and the ozone generator, cracks are visible in the check valve body, or foreign matter has built up on the internal O-ring, replacement should be performed immediately, regardless of elapsed time since last replacement.

Required replacement schedule is listed below, and must be performed on schedule, even if the check valve appears sound.

Frequency of Replacement:

Every 3 months

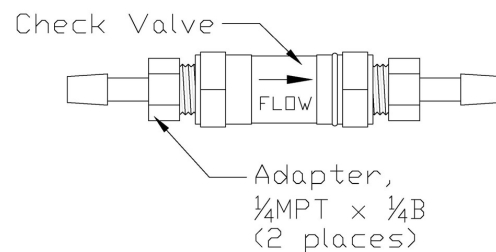

FIGURE 4 – CHECK VALVE ASSEMBLY

To Replace Check Valve

1. Disconnect unit from power source. Allow the ozone generator to clear of ozone gas.
2. Remove tubing from hose adapter on each end of the check valve.
3. Trim approximately one inch from the end of each tube, to remove distortion caused by the hose adapter.
4. Locate two new hose adapters supplied with the maintenance kit, and apply Teflon tape (or equivalent) to male threads.
5. Install one hose adapter into each end of the check valve, using care to avoid damage to the check valve body.
6. Place new check valve assembly in-line, between ozone generator and venturi injector. Check valve flow direction must point toward venturi.

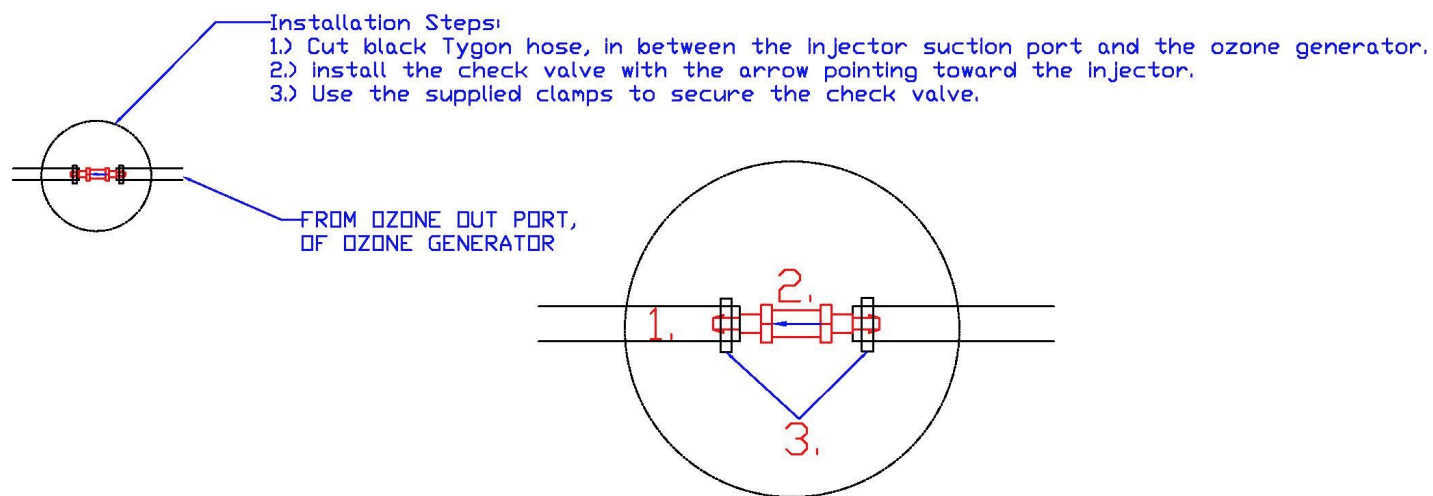

FIGURE 5 – CHECK VALVE INSTALLATION, (DETAIL)

5.0 Fusing

There is only one fuse, connected to the live source conductor and accessible from the outside of the chassis. The figure below illustrates location of this fuse. Fuse size and value is listed below:

Model #	Fuse Size	Fuse Value
115 Vac Models	1/4"x1 1/4"	1.5 amp Fast Acting,
230Vac Models (Foreign)	5mmx20mm	1.6A Time delay, IEC127

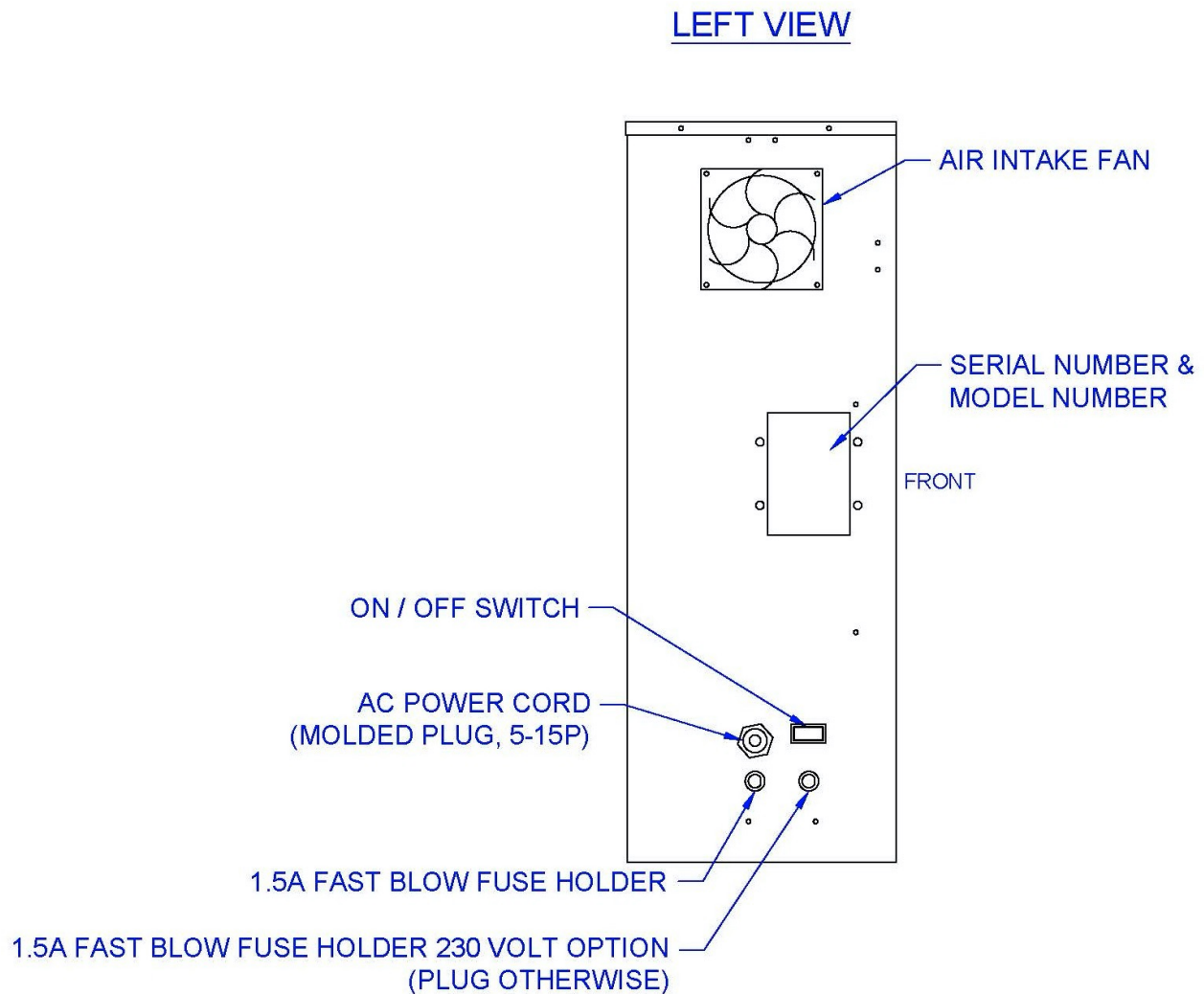

FIGURE 6 – FUSE LOCATION (LEFT SIDE CHASSIS COMPONENT DETAILS)

6.0 Spare/Replacement Parts

(*) Denotes recommended spare maintenance parts with initial purchase. Followed by quantity, per unit, recommended for one year scheduled maintenance.

(**) Denotes recommended spare parts for purchases outside of the Continental U.S., or for applications where it is necessary to eliminate potential down time (i.e., bottled water stores). Items marked with this symbol should be purchased in addition to those marked with (*) symbol.

Part No.	Description	Applicable Model
40155	Corona Discharge Cell Interface upgrade assembly**	All models Qty = (1), AIM 2 BTU Qty = (2), AIM 5 BTU Cells may be replaced
individually		
40147 Primary**	High Voltage Transformer,	115Vac Models 115Vac
40147-01 Primary**	High Voltage Transformer,	230Vac Models 230Vac
33241	Manifold Assembly, Single**	All models Qty = (1), OZ1 BTU Qty = (2), OZ2 BTU Manifold Assemblies may be replaced individually.
40104	Step-down Transformer**	All models
31072	Flow meter, 0-10 SCFH	All models
43002	Indicator light	All models
40002	Fan	All models
40013	Fan Guard	All models
38097	Filter Media* (Qty = 2)	All models
44344	O-Ring, Viton	All models Qty = (1) per H.V. Cap

6.0 Spare/Replacement Parts (contd.)

Part No.	Description	Applicable Model
43025-01	Fuse, 1.5A Fast Blo* (Qty = 1)	All models
43228	Fuse, IEC127, 1.6A Time delay* 5mm x 20mm	All models
44347	Tension Retainer Assembly	All models
45264	CD Cell Cap assy.	All models
44345	CD Cell retaining cup	All models
34460	CD Cell tension spring	All models
44346	CD Cell retaining cup gasket	All models
47011	Check Valve, ½#* (Qty = 1)	All models; included in accessory packet
44134	Snapper Clamp, #4	All models
44140	Tubing, Tygon 1/4" I.d. x 3/8" O.d.	All models
44144	Snapper Clamp, #2	All models
44244	Tubing, Tygon 1/4" I.d. x 7/16" O.d.	All models

Note: Spare parts are listed for only the most commonly purchased models. For options not included in this section, consult your dealer.

7.0 Troubleshooting Guide

Troubleshooting should be performed by a qualified electrician, in accordance with sound electrical safety practices.

Symptom	Possible Cause	Remedy
Indicator light does not turn on.	Unit is not connected to power source, or is connected to improper power source.	Refer to label on side of chassis for voltage/frequency requirements. Connect unit to proper power source.
	Safety Interlock Switch is not engaged by chassis lid.	Remove lid. Bend "up" interlock arm.
	Fuse is blown.	Visually inspect unit, and compare to wiring diagram. Inspect Corona Discharge Cell for damage. Inspect wire from High Voltage Transformer to Corona Discharge Cell for disconnection or burn marks. Repair any and all problems prior to placing unit in service, or contact factory for service information.
	Light is not receiving power.	Connect light leads to power source per wiring diagram.
	Light has failed	Refer to Spare/Replacement Parts for replacement part information.
Unit keeps blowing fuses.	Electrical short circuit.	Visually inspect unit, and compare to wiring diagram. Inspect Corona Discharge Cell for damage. Inspect wire from High Voltage Transformer to Corona Discharge Cell for disconnection or burn marks. Repair any and all problems prior to placing unit in service, or contact factory for service information.
	Incorrect fuse value and type are being used.	Compare fuse to label on side of unit. Replace with appropriate size/type fuse. Refer to Spare/Replacement Parts for replacement part information.
	Unit is connected to improper power source.	Refer to label on side of chassis for voltage/frequency requirements.
	Corona Discharge Cells were not installed.	Install per Installation Manual. (Corona Discharge Cells are shipped in a separate container to avoid damage).
	Corona outside of the Cell/Manifold has established due to dirt or moisture within chassis. Corona Discharge Cell is in need of maintenance.	Perform Corona Discharge Cell maintenance and Chassis maintenance in accordance with this manual.
Unit does not produce adequate concentration of ozone.	Air flow rate is too high.	Adjust air flow meter to lower setting, within range specified in Air Flow Specification section of this manual.
	Unit is running too hot due to insufficient cooling air flow.	Refer to Air Flow Specification section of this manual.
	Unit is connected to improper power source.	Refer to label on side of chassis for voltage/frequency requirements.
Unit does not produce adequate concentration of ozone, even with air flow rate set at levels that previously produced adequate ozone concentration.	Corona Discharge Cells require maintenance.	Refer to Corona Discharge Cell Maintenance Section of this manual.
	Air preparation device is not functioning at prior level of performance.	Inspect/Maintain air preparation equipment in accordance with manufacturer recommendations.

8.0 Standards

The transformer(s) in this unit are manufactured and tested (as applicable) to the following standards.

High voltage transformer, all models (Part No. 40141)
Underwriters Laboratories E176017

Step-down transformer, 230Vac models (Part No. 40104)
Underwriters Laboratories E86403 EN 60742

CHASSIS - BACK VIEW

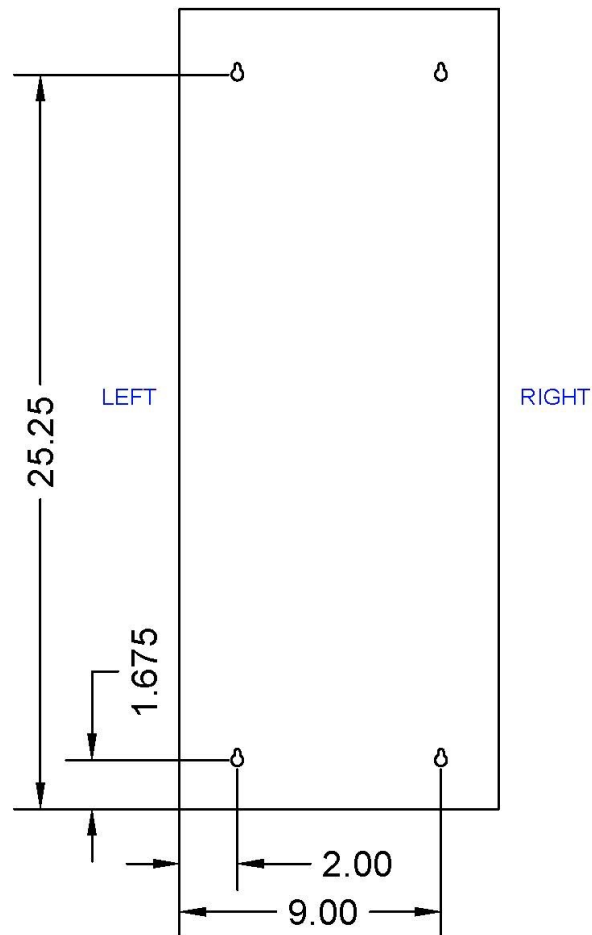

FIGURE 7 – AIM 2 BTU & AIM 5 BTU MOUNTING HOLE LOCATIONS

9.0 Limited Warranty

OZOTECH, Inc., warrants the AIM 2 BTU and AIM 5 BTU oone generators to be free from defects in parts and workmanship for (12) months from date of invoice, under conditions of normal use. The corona discharge cell is warrantied against catastrophic electrical failure for 3 years from date of invoice. All other parts, repaired or replaced, will be warranted only for the remainder of the original warranty period.

OZOTECH, Incorporated will refund the purchase price, perform repairs or replace equipment, at the option of OZOTECH, Incorporated.

The warranty shall be null, void, and non-binding upon OZOTECH, Incorporated if OZOTECH, Incorporated (or authorized service center) determines the cause of malfunction or defect to be a result of:

1. Failure to perform proper maintenance as defined and recommended in this manual.
2. Failure to adhere to and provide proper operating conditions, as defined in this manual, including operation outside of temperature range, operating in wet or dirty environment, operation outside of manufacturer's specifications.
3. Adjustments made by user other than product output flow rate within ranges specified by manufacturer.

OZOTECH, Incorporated assumes no liability for damages incurred by deliberate or incidental misuse of this product, or damages incurred in transit.

Read Limited Product Warranty>[Link](#)

10.0 Service Returns

If the need arises to return your equipment for service, the following procedure must be followed to ensure accurate and timely processing of repairs.

- ✓Obtain the serial number of unit to be returned.
- ✓Obtain model number/name of unit to be returned.
- ✓Contact Ozotech, Incorporated and request a Return Material Authorization (RMA) form. Make sure to give the factory representative an accurate and current shipping address.
- ✓Enclose a description detailing the problem with the unit. Be as specific as possible.
- ✓After receipt of RMA form, package unit for shipment. Enclose the RMA form with the unit. Use the original packaging materials if possible.
- ✓Clearly write the RMA number on the outside of the shipping package.
- ✓Verify that the address is correct and current.
- ✓Shipments that are not factory authorized will be refused.

It is recommended that you ship with a reputable and reliable shipping company, and that the contents of the package are insured. Ozotech, Inc., accepts no responsibility for damage or loss of equipment in transit.

ALL FREIGHT CHARGES INTO THE FACTORY MUST BE PREPAID. If the repair is covered under warranty, the factory will pay return shipping charges (surface rates only) to the address listed on the RMA, within the Continental United States. If the repair is not covered under warranty, the returning party is responsible for payment of return shipping and handling charges, as well as labor and equipment costs associated with the repair.

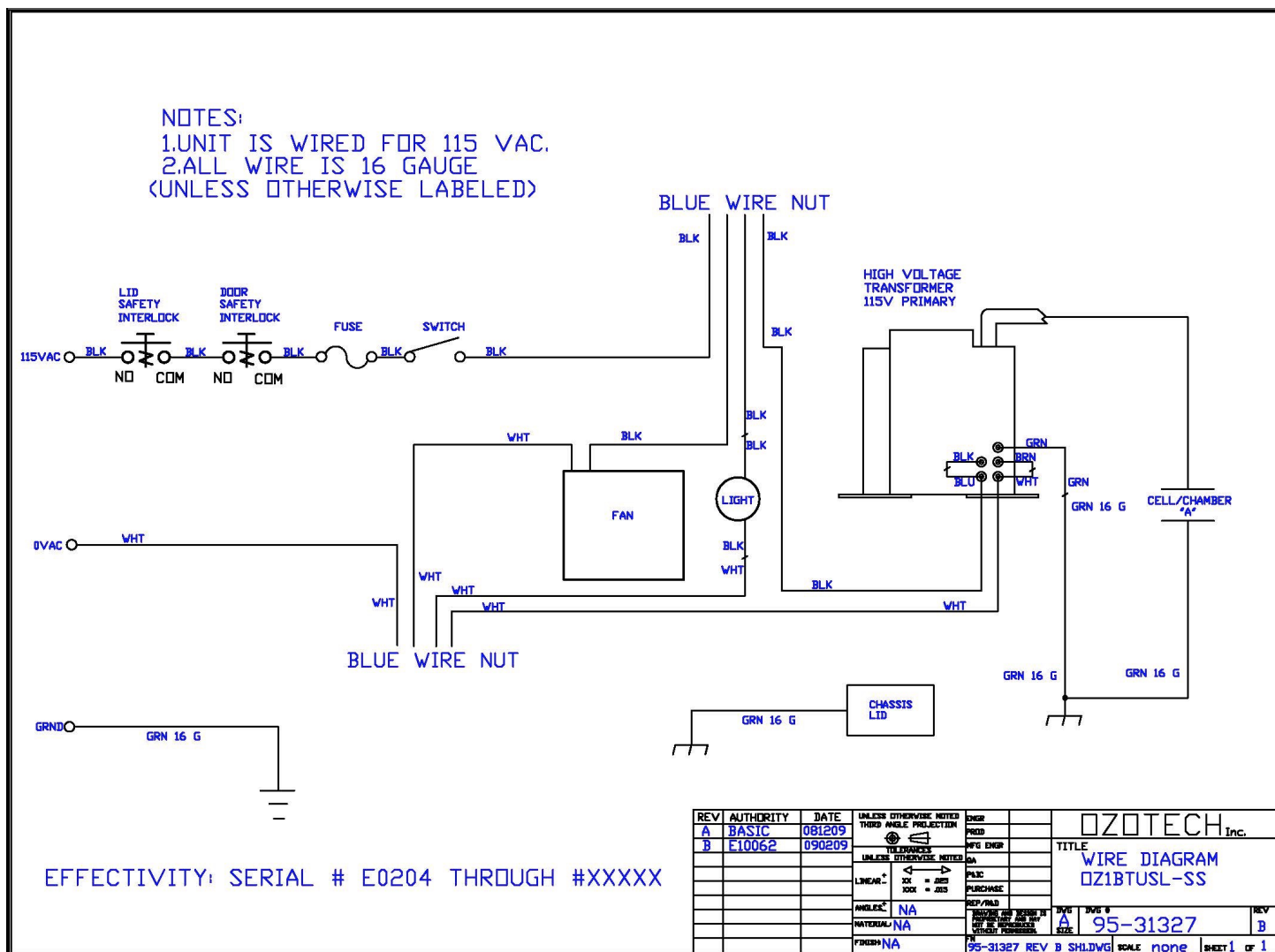

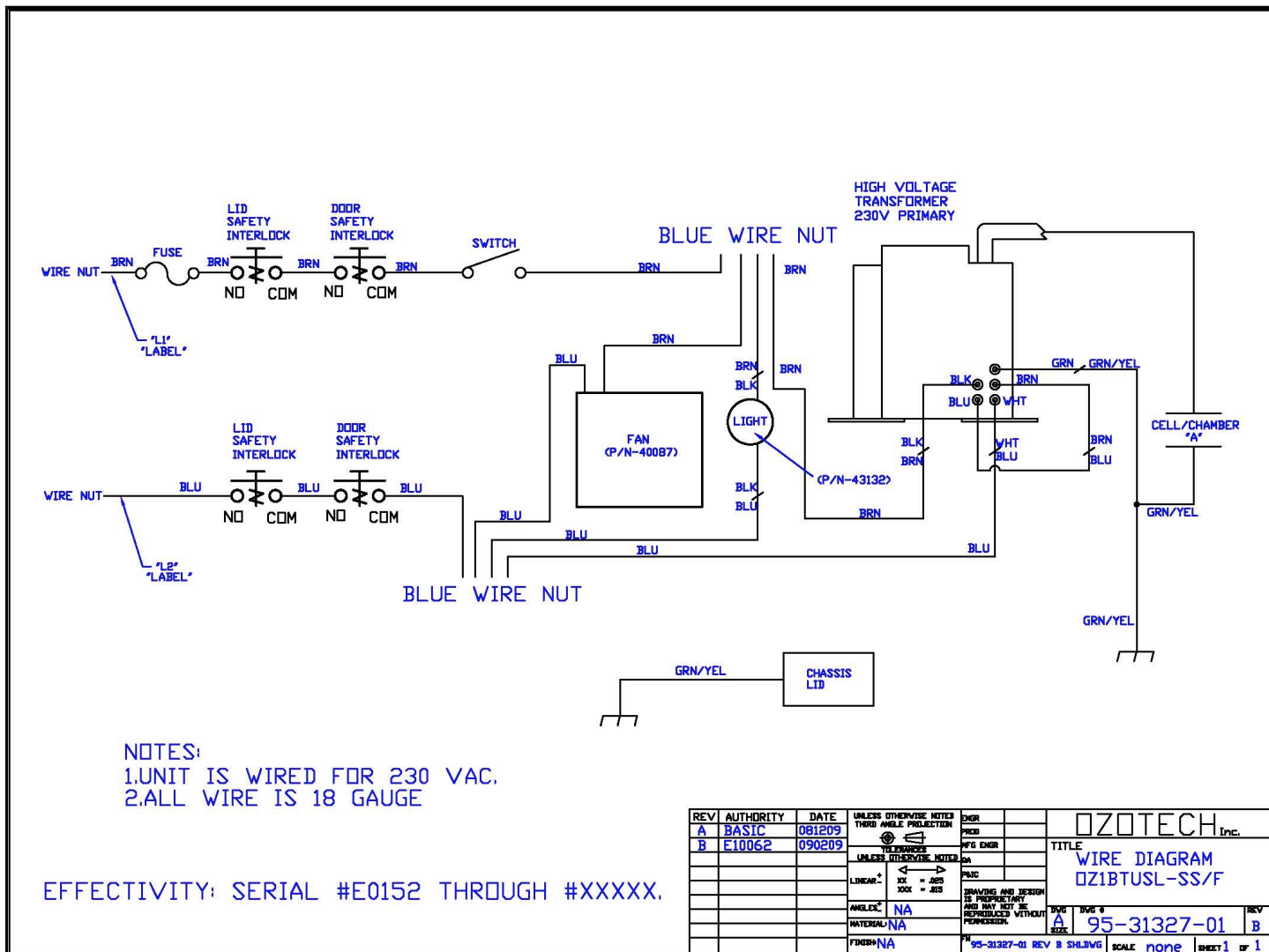

FIGURE 9 – AIM 2 BTU WIRING DIAGRAM, 230vac 50/60Hz.